



# Current Transformer

## Model 7

**APPLICATION:**

With ammeters, wattmeters and cross current compensation.

**FREQUENCY:**

50-400 Hz.

**INSULATION LEVEL:**

600 Volts. 10 kV BIL. full wave

**WINDOW DIAMETER:**

2.50"

**APPROXIMATE WEIGHT:**

1.5 lbs.

**CONNECTIONS:**

-Flexible leads are UL 1015 105 C, CSA approved #16 AWG, 24" long

-Non-standard length to be specified

-Terminals are brass studs No. 8-32 UNC with one flat washer, lockwasher, and regular nut

-SFT and SHT case styles also available as SFL and SHL with leads

-Mounting kit 0221B00182



Model	7SHT	7SFT	7RL
Window Size	2.50	2.50	2.50
Width	4.56	4.56	4.58
Height	4.85	4.85	4.58
Depth	1.10	1.08	1.10

**CERTIFICATIONS:**



**MODEL 7**  
Window Diameter 2.50"  
Approximate weight: 1.5 lbs.

CATALOG NUMBER	CURRENT RATIO	ACCURACY AT 60 HZ	BURDEN VA AT 60 HZ
7**-101	100:5	+ 2%	2.5
7**-151	150:5	+ 1%	5
7**-201	200:5	+ 1%	5
7**-251	250:5	+ 1%	5
7**-301	300:5	+ 1%	12.5
7**-401	400:5	+ 1%	15
7**-501	500:5	+ 1%	25
7**-601	600:5	+ 1%	30
7**-751	750:5	+ 1%	30
7**-801	800:5	+ 1%	35
7**-102	1000:5	+ 1%	35
7**-122	1200:5	+ 1%	35
7**-152	1500:5	+ 1%	40
7**-162	1600:5	+ 1%	45

Note: When ordering, prefix Cat No. with model designation required, i.e. 7SFT-500, 7RL-500, etc.

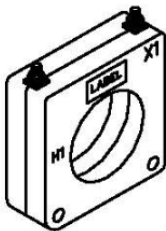

7SHT

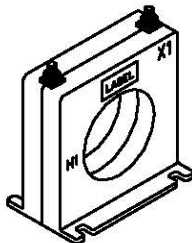

7SFT

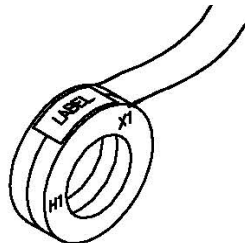

7RL

Products are manufactured in a plant whose quality management system is certified / registered as being in conformity with ISO 9001

7SHT

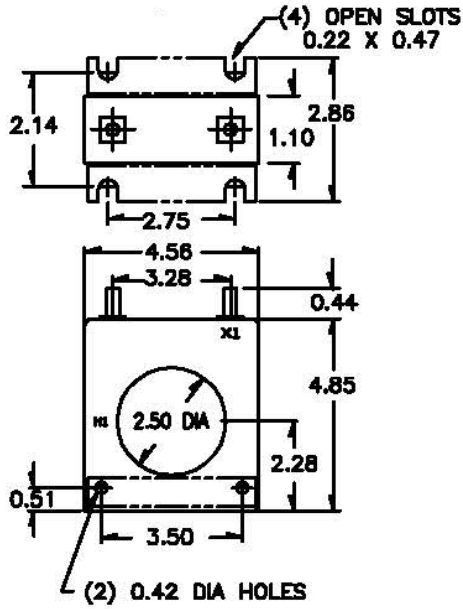

7SFT

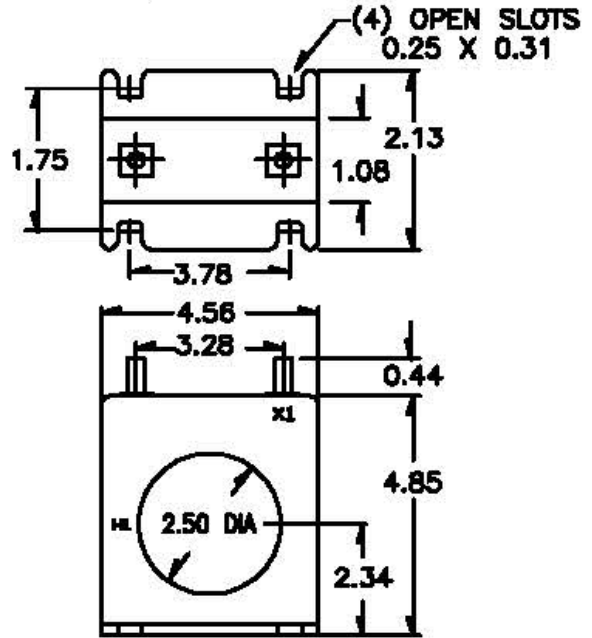

7RL

