

Rotary Position Technology Incremental Encoders

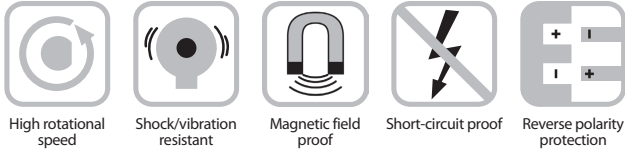

Universal, type 580x (shaft) / 582x (hollow shaft)



High rotational speed Shock/vibration resistant Magnetic field proof Short-circuit proof Reverse polarity protection

Rugged

- Short-circuit proof outputs
- Reverse connection protection (at +V= 10-30 VDC)
- Highly flexible PUR-cable
- High shaft load
- 5803/5823: High temperature up to 230°F (110°C)
- 5826: Stainless steel housing



Compact

- Ø 58 mm housing, industry standard

Versatile

- Shaft/hollow shaft
- 5800/5820: Standard
- 5804/5824: Voltage sine wave outputs
- 5805: High resolution up to 36000 ppr
- Many variations, also customized versions

Mechanical characteristics:

Speed with seal:	Shaft version: max. 12,000 RPM Hollow shaft version ⁴⁾ : max. 6,000 RPM
Speed without seal:	Hollow shaft version max. 12,000 RPM
Rotor moment of inertia:	Shaft version: approx. 0.098 oz-in ² (1.8 x 10 ⁻⁶ kgm ²) Hollow shaft version: approx. 0.328 oz-in ² (6 x 10 ⁻⁶ kgm ²)
Starting torque:	Shaft version: < 1.4 oz-in (< 0.01 Nm) Hollow shaft version: < 7 oz-in (<0.05 Nm)
Radial load capacity of the shaft*:	18 lbs (80 N)
Axial load capacity of the shaft*:	9 lbs (40 N)
Weight:	approx. 0.9 lbs (0.4 kg)

Protection acc. to EN 60 529 :	IP65, IP66 for type 5826
EX approval for hazardous areas:	optional zone 2 and 22
Working temperature:	-4 to +185°F (-20 to +85°C) ^{1) 2) 3)} 5803/5823: -4 to +221°F (-20 to + 105°C)

Materials:

Shaft/hollow shaft: stainless steel
Housing: Aluminum (stainless steel: 5826)
Flange: Aluminum (stainless steel: 5826)
Cable: PVC

Shock resistance acc. to DIN-IEC 68-2-27:	approx. 100 g (1000 m/s ²), 6 ms
Vibration resistance acc. to DIN-IEC 68-2-6:	approx. 10 g (100 m/s ²), 10-2000 Hz

¹⁾ Constant flexing: -4 to +158°F (-20+70°C)

²⁾ Non-condensing

³⁾ Hollow shaft version with seal: -4 to +176°F (-20+80°C)

⁴⁾ For continuous operation 6,000 RPM, ventilated

Electrical characteristics sine wave output:

Output circuit:	Sine wave U = 1 Vpp	Sine wave U = 1 Vpp
Supply voltage:	5 VDC (±5%)	10-30 VDC
Current consumption (no load) with inverted signals:	typ. 65 mA / max. 110 mA	typ. 65 mA / max. 110 mA
-3 dB frequency:	≤180 kHz	≤180 kHz
Signal channels A/B:	1 Vpp (±20%)	1 Vpp (±20%)
Signal channels 0:	0.1-1.2 V	0.1-1.2 V
Short-circuit proof outputs ¹⁾ :	yes	yes
Reverse connection protection at +V:	no	yes
Conforms to CE requirements acc. to EN 61000-6-1, EN 61000-6-4 and EN 61000-6-3		
RoHS compliant acc. to EU guideline 2002/95/EG		

¹⁾ If supply voltage correctly applied

Universal, type 580x (shaft) / 582x (hollow shaft)

Electrical characteristics RS422 / Push-pull:

Output circuit:	RS 422 (TTL compatible)	RS 422 (TTL compatible)	Push-pull (IC-WE) ¹⁾	Push-pull (7272) ¹⁾	Open collector (7273)
Shaft Part Key	4,5	Y	6	T	R
Hollow Shaft Part Key	1,4	7	3	C	B
Supply voltage:	5 VDC (±5 %) or 10-30 VDC	5-30 VDC	10-30 VDC	5-30 VDC	5-30 VDC
Power consumption (no load) without inverted signal:	-	-	typ. 55 mA / max. 125 mA	typ. 55 mA / max. 125 mA	100 mA
Power consumption (no load) with inverted signal:	typ. 40 mA / max. 90 mA	typ. 40 mA / max. 90 mA	typ. 80 mA / max. 150 mA	typ. 80 mA / max. 150 mA	100 mA
Permissible load/channel:	max. ±20 mA	max. ±20 mA	max. ±30 mA	max. ±30 mA	20 mA sink @ 30 VDC
Pulse frequency:	max. 300 kHz	max. 300 kHz	max. 300 kHz	max. 300 kHz	max. 300 kHz
Signal level high:	min. 2.5 V	min. 2.5 V	min. +V -2.5 V	min. +V -1.5 V	n/a
Signal level low:	max. 0.5 V	max. 0.5 V	max. 2.0 V	max. 2.0 V	n/a
Rise time t _r :	max. 200 ns	max. 200 ns	max. 1 μs	max. 1 μs	
Fall time t _f :	max. 200 ns	max. 200 ns	max. 1 μs	max. 1 μs	
Short-circuit proof outputs ¹⁾ :	yes ²⁾	yes ²⁾	yes	yes	yes
Reverse connection protection at +V:	5 V: no, 10-30 V: yes	yes	yes	no	no
UL certified:	File 224618				

Conforms to CE requirements acc. to EN 61000-6-1, EN 61000-6-4 and EN 61000-6-3

RoHS compliant acc. to EU guideline 2002/95/EG

¹⁾ If supply voltage correctly applied

²⁾ Only one channel allowed to be shorted-out: (If +V = 5 V, short-circuit to channel, 0 V, or +V is permitted) (If +V = 5-30 V, short-circuit to channel or 0 V is permitted)

Standard wiring / pin configuration:

Output:	Case Ground	Common (0 V)	+V	A	\bar{A}	B	\bar{B}	Z	\bar{Z}	-	-	Com / Sensor	+V Sensor
M23 <i>multifast</i> [®]	Coupling Nut	10	12	5	6	8	1	3	4	-	-	11	2
MS 7-pin	G	F	D	A	-	B	-	C	-	-	-	-	E
MS 10-pin	J	F	D	A	G	B	H	C	I	-	-	-	E
M12 <i>eurofast</i> [®]	Coupling Nut	1	2	3	4	5	6	7	8	-	-	-	-
Cable:	Shield/Drain	WH	BN	GN	YE	GY	PK	BU	RD	BK	VT	GY/PK	RD/BU

Special connector pin configuration:

	Output:	Case Ground	Common (0 V)	+V	A	\bar{A}	B	\bar{B}	Z	\bar{Z}	-	-	
Output Code	07	M12 <i>eurofast</i>	Coupling Nut	7	2	1	3	4	5	6	8	-	-
	02	MS 7-pin	G	F	D	A	C	B	E	-	-	-	-
	03	MS 7-pin	G	F	D	A	-	B	-	C	-	-	-
	04	MS 7-pin	G	F	D	A	C	B	E	-	-	-	-
	05	MS 7-pin	G	F	D	A	-	B	-	C	-	-	-
	06	MS 10-pin	G	F	D	A	H	B	I	C	J	-	-

Wiring diagrams:

Male encoder view			
M12 <i>eurofast</i> pinout	M23 <i>multifast</i> pinout	MS pinout (7-pin)	MS pinout (10-pin)
Mating cordset: E-RKC 8T-930-*	Mating cordset: E-CKM 12-931-*	Mating cordset: E-MK 7-930-*	Mating cordset: E-MK 10-931-*

* Length in meters.

Rotary Position Technology

Incremental Encoders



Universal, type 5803 (shaft) / 5823 (hollow shaft)

Part number key: 5803 shaft version

T8.5803.XXXX.XXXX.PXXXX

Options for special output only.

Type

3 = high temperature

Flange

1 = Ø 58 clamping flange
 2 = Ø 58 servo flange
 M = 2.5" (Ø 63.5 mm) square flange
 P = 2.5" (Ø 63.5 mm) servo flange
 Z = 2.5" (63.5 mm) square flange with shaft seal

Shaft (Ø x L)

1 = Ø 6 mm x 10 mm
 2 = Ø 10 mm x 20 mm
 P = Ø 3/8" x 7/8"

Voltage supply and output circuit

Type 5803

4 = 5 VDC, RS422 *
 5 = 10-30 VDC, RS422 *
 6 = 10-30 VDC, push-pull *
 R = 5-30 VDC, open collector *(7273)
 T = 5-30 VDC, push/pull *(7272)

Special connector pin configuration

See page E26

Special Output Signal Formats

See page E62

Pulse rate

1, 5, 10, 15, 20, 25, 30, 50, 60, 100, 125, 200, 250, 256, 300, 360, 500, 512, 600, 700, 720, 800, 900, 1000, 1024, 1200, 1250, 1500, 1800, 2000, 2048, 2400, 2500, 3000, 3600, 4000, 4096, 5000
 (e.g. 250 pulses => 0250)
 Other pulse rates available on request

Type of connection

1 = axial cable (1 m PUR cable)
 2 = radial cable (1 m PUR cable)
 3 = axial 12-pin M23 **multifast**® plug without mating connector
 5 = radial 12-pin M23 **multifast** plug without mating connector
 W = radial MS, 7-pin (MS 3102R16S-1P)
 Y = radial MS, 10-pin (MS3102A18-1P)

* With inverted signal

Part number key: 5823 hollow shaft version

T8.5823.XXXX.XXXX.PXXXX

Options for special output only.

Type

3 = high temperature

Flange

1 = flange for through shaft
 2 = flange for blind hollow shaft ¹⁾
 3 = flange for through shaft and flex mount
 4 = flange for blind hollow shaft and flex mount ¹⁾
 length of drive shaft ≤ 30 mm

Hollow shaft

1 = Ø 6 mm without seal	A = Ø 1/2"
2 = Ø 6 mm with seal	B = Ø 1/4"
3 = Ø 8 mm without seal	K = Ø 3/8" with seal
4 = Ø 8 mm with seal	R = Ø 3/8"
5 = Ø 10 mm without seal	S = Ø 1/4" with seal
7 = Ø 12 mm without seal	U = Ø 1/2" with seal

* With inverted signal

Special connector pin configuration

See page E26

Special Output Signal Formats

See page E62

Pulse rate

1, 5, 10, 15, 20, 25, 30, 50, 60, 100, 120, 125, 150, 180, 200, 240, 250, 256, 300, 360, 400, 500, 512, 600, 700, 720, 800, 900, 1000, 1024, 1200, 1250, 1500, 1800, 2000, 2048, 2400, 2500, 3000, 3600, 4000, 4096, 5000
 (e.g. 250 pulses => 0250)
 Other pulse rates available on request

Type of connection

1 = radial cable (1 m PVC cable)
 2 = radial 12-pin M23 **multifast** plug without mating connector
 C = radial 8-pin M12 **eurofast** connector ¹⁾

Voltage supply and output

Type 5823

1 = 5 VDC, RS422 *
 3 = 10-30 VDC, push-pull *
 4 = 10-30 VDC, RS422 *
 C = 5-30 VDC, push-pull *(7272)

Accessories:

- See page J1, Connectivity, for cables and connectors
- See page G1, Accessories, for mounting attachments and couplings

Universal, type 5804 (shaft) / 5824 (hollow shaft)

Part number key: 5804 shaft version

T8.5804.XXXX.XXXX.PXXXX

Options for special output only.

Type
4 = sine wave

Flange
1 = Ø 58 clamping flange
2 = Ø 58 servo flange

Shaft (Ø x L)
1 = Ø 6 mm x 10 mm
2 = Ø 10 mm x 20 mm

Voltage supply and output circuit
Type 5804¹⁾
1 = 5 VDC, sine, 1 Vpp*
2 = 10-30 VDC, sine, 1 Vpp*

Special connector pin configuration
See page E26

Special Output Signal Formats
See page E62

Pulse rate
1, 5, 10, 15, 20, 25, 30, 50, 60, 100, 125, 200, 250, 256, 300, 360, 500, 512, 600, 700, 720, 800, 900, 1000, 1024, 1200, 1250, 1500, 1800, 2000, 2048, 2400, 2500, 3000, 3600, 4000, 4096, 5000
Other pulse rates available on request

Type of connection
1 = axial cable (1 m PUR cable)
2 = radial cable (1 m PUR cable)
3 = axial 12-pin M23 **multifast**® plug without mating connector
5 = radial 12-pin M23 **multifast** plug without mating connector
G = radial 8-pin M12 **eurofast**® connector
T = axial 8-pin M12 **eurofast** connector

¹⁾ P04XX is the only option code for 5804
* With inverted signal

Part number key: 5824 hollow shaft version

T8.5824.XXXX.XXXX.PXXXX

Options for special output only.

Type
4 = sine wave

Flange
1 = flange for through shaft
2 = flange for blind hollow shaft¹⁾
3 = flange for through shaft and flex mount
4 = flange for blind hollow shaft and flex mount¹⁾
length of drive shaft ≤ 30 mm

Hollow shaft

1 = Ø 6 mm without seal	A = Ø 1/2"
2 = Ø 6 mm with seal	B = Ø 1/4"
3 = Ø 8 mm without seal	J = Ø 1/2"
4 = Ø 8 mm with seal	K = Ø 3/8" with seal
5 = Ø 10 mm without seal	R = Ø 3/8"
7 = Ø 12 mm without seal	S = Ø 1/4" with seal
	U = Ø 1/2" with seal

Special connector pin configuration
See page E26

Special Output Signal Formats
See page E62

Pulse rate
1, 5, 10, 15, 20, 25, 30, 50, 60, 100, 120, 125, 150, 180, 200, 240, 250, 256, 300, 360, 400, 500, 512, 600, 700, 720, 800, 900, 1000, 1024, 1200, 1250, 1500, 1800, 2000, 2048, 2400, 2500, 3000, 3600, 4000, 4096, 5000
(e.g. 250 pulses => 0250)
Other pulse rates available on request

Type of connection
1 = radial cable (1 m PVC cable)
2 = radial 12-pin M23 **multifast** plug without mating connector
C = radial 8-pin M12 **eurofast** connector¹⁾

* With inverted signal

Voltage supply and output
Type 5824
1 = 5-30 VDC, sine, 1 Vpp*
2 = 10-30 VDC, sine, 1 Vpp*

Accessories:

- See page J1, Connectivity, for cables and connectors
- See page G1, Accessories, for mounting attachments and couplings

Rotary Position Technology

Incremental Encoders



Universal, type 5805 (shaft) / 5825 (hollow shaft)

Part number key: 5805 shaft version

T8.5805.XXXX.XXXX.PXXXX

Options for special output only.

Type

5 = high resolution

Flange

1 = Ø 58 clamping flange
 2 = Ø 58 servo flange
 M = 2.5" (Ø 63.5 mm) square flange
 P = 2.5" (Ø 63.5 mm) servo flange
 Z = 2.5" (63.5 mm) square flange with shaft seal

Shaft (Ø x L)

1 = Ø 6 mm x 10 mm
 2 = Ø 10 mm x 20 mm
 P = Ø 3/8" x 7/8"

Voltage supply and output circuit

Type 5805¹⁾
 4 = 5 VDC, RS422 *
 5 = 10-30 VDC, RS422 *
 6 = 10-30 VDC, push-pull *
 T = 5-30 VDC, push/pull *(7272)
 Y = 5-30 VDC, RS422 *

Special connector pin configuration

See page E26

Special Output Signal Formats

See page E62

Pulse rate

6000, 7200, 8000, 8192, 9000, 10000, 18000, 20000, 36000
 Other pulse rates available on request

Type of connection

1 = axial cable (1 m PUR cable)
 2 = radial cable (1 m PUR cable)
 3 = axial 12-pin M23 **multifast**® plug without mating connector
 5 = radial 12-pin M23 **multifast** plug without mating connector
 G = radial 8-pin M12 **eurofast**® connector
 T = axial 8-pin M12 **eurofast** connector

¹⁾ P04XX is the only option code for 5805
 * With inverted signal

Part number key: 5825 hollow shaft version

T8.5825.XXXX.XXXX.PXXXX

Options for special output only.

Type

5 = high resolution

Flange

1 = flange for through shaft
 2 = flange for blind hollow shaft
 3 = flange for through shaft and flex mount
 4 = flange for blind hollow shaft and flex mount
 length of drive shaft ≤ 30 mm

Hollow shaft

1 = Ø 6 mm without seal K = Ø 3/8" with seal
 2 = Ø 6 mm with seal U = Ø 1/2" with seal
 3 = Ø 8 mm without seal
 4 = Ø 8 mm with seal
 5 = Ø 10 mm without seal
 7 = Ø 12 mm without seal

Special connector pin configuration

See page E26

Special Output Signal Formats

See page E62

Pulse rate

6000, 7200, 8000, 8192, 9000, 10000, 18000, 20000, 36000
 Other pulse rates available on request

Type of connection

1 = radial cable (1 m PVC cable)
 2 = radial 12-pin M23 **multifast** plug without mating connector
 C = radial 8-pin M12 **eurofast** connector

Voltage supply and output

Type 5825
 1 = 5 VDC, RS422 *
 3 = 10-30 VDC, push-pull *
 4 = 10-30 VDC, RS422 *
 C = 5-30 VDC, push-pull *(7272)

¹⁾ Not for type 5826
²⁾ Only for type 5826
³⁾ Only for type 5824
 * With inverted signal

Accessories:

- See page J1, Connectivity, for cables and connectors
- See page G1, Accessories, for mounting attachments and couplings

Incremental Encoders

Universal, type 5826 (hollow shaft)

Part number key: 5826 hollow shaft version

T8.5826.XXXX.XXXX.PXXXX

Options for special output only.

Type

6 = stainless steel

Flange

1 = flange for through shaft
3 = flange for through shaft and flex mount

Hollow shaft

6 = Ø 10 mm with seal ²⁾
8 = Ø 12 mm with seal ²⁾
K = Ø 3/8" with seal
S = Ø 1/4" with seal
U = Ø 1/2" with seal

* With inverted signal

Special connector pin configuration

See page E26

Special Output Signal Formats

See page E62

Pulse rate

1, 5, 10, 15, 20, 25, 30, 50, 60, 100, 120, 125, 150, 180, 200, 240, 250, 256, 300, 360, 400, 500, 512, 600, 700, 720, 800, 900, 1000, 1024, 1200, 1250, 1500, 1800, 2000, 2048, 2400, 2500, 3000, 3600, 4000, 4096, 5000
(e.g. 250 pulses => 0250)
Other pulse rates available on request

Type of connection

1 = radial cable (1 m PVC cable)
2 = radial 8-pin M12 **eurofast** connector

Voltage supply and output

Type 5826

1 = 5 VDC, RS422 *
3 = 10-30 VDC, push-pull *
4 = 10-30 VDC, RS422 *
7 = 5-30 VDC, RS422 *
B = 5-30 VDC, open collector *(7273)
C = 5-30 VDC, push-pull* (7272)

Accessories:

- See page J1, Connectivity, for cables and connectors
- See page G1, Accessories, for mounting attachments and couplings

Universal, type 580x (shaft) / 582x (hollow shaft)

Dimensions: 580X shaft version

580X flange
Connection G

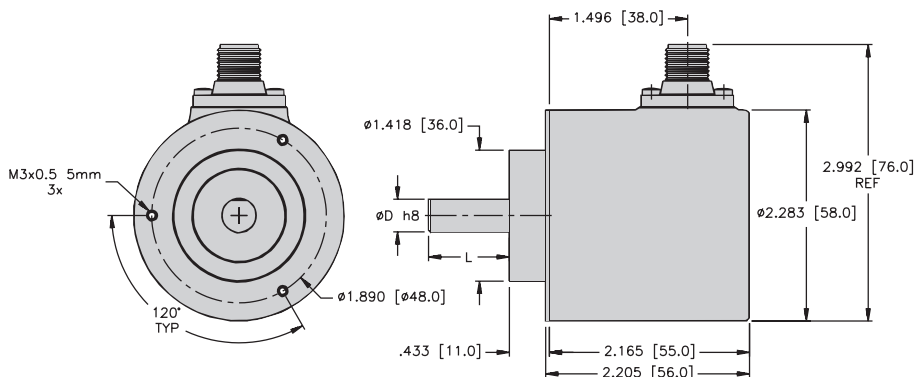

580X flange
Connection T

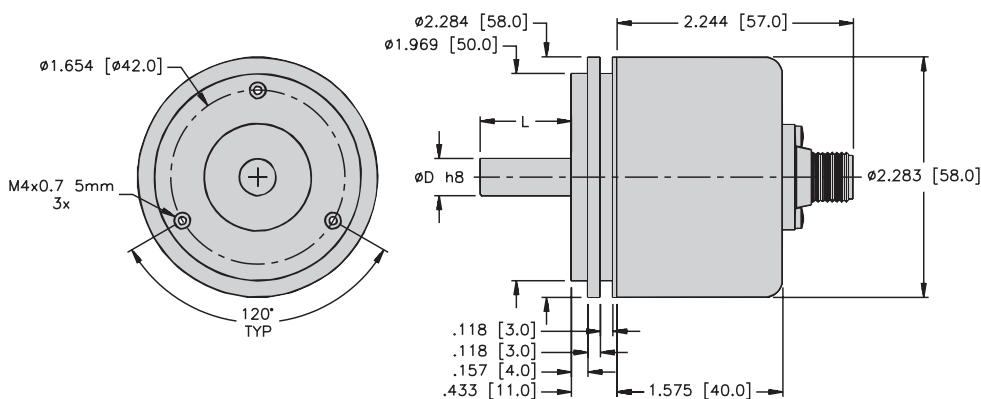

Mounting advice:

The flanges and shafts of the encoder and drive should not be rigidly coupled together at the same time. We recommend the use of suitable couplings (see page G1, Accessories).

Incremental Encoders

Universal, type 580X (shaft) / 582X (hollow shaft)

Dimensions: 580X shaft version

580X flange M & Connection 1 & 2

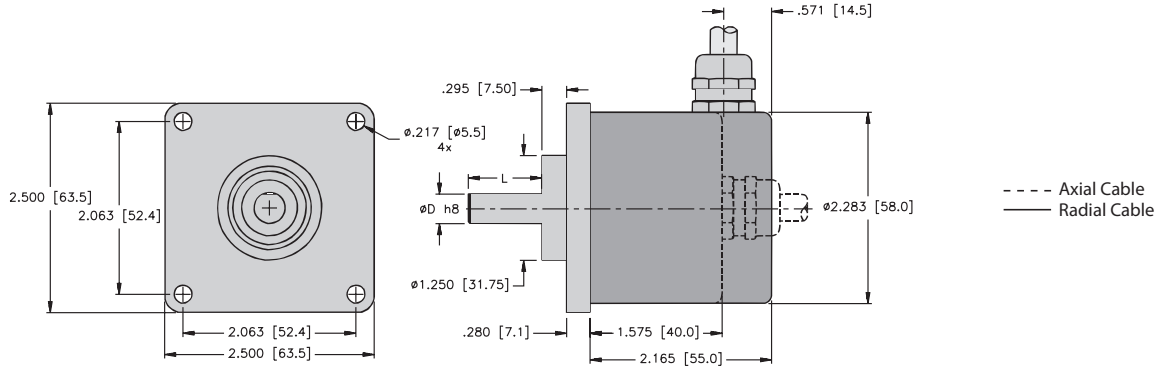

580X flange Connection W & Y

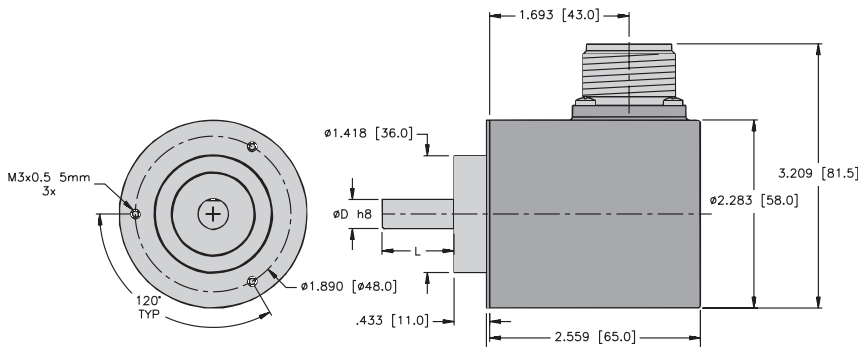

580X flange Connection 3

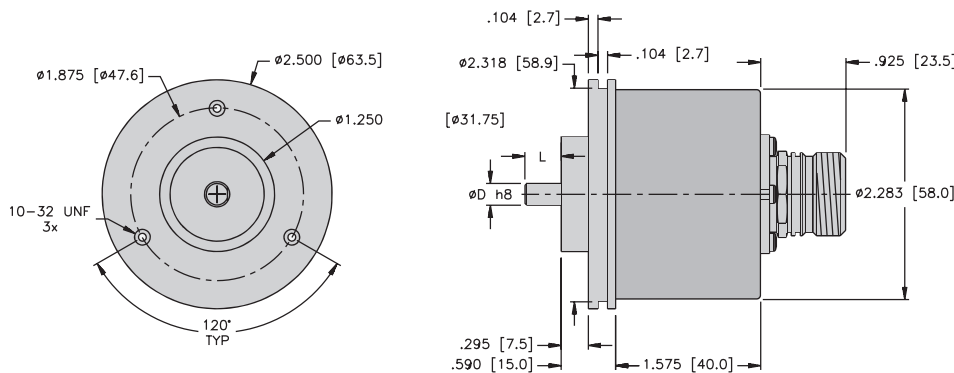

Mounting advice:

The flanges and shafts of the encoder and drive should not be rigidly coupled together at the same time. We recommend the use of suitable couplings (see page G1, Accessories).

Rotary Position Technology Incremental Encoders



Universal, type 580X (shaft) / 582X (hollow shaft)

Dimensions: 580X shaft version

580X flange
Connection 5

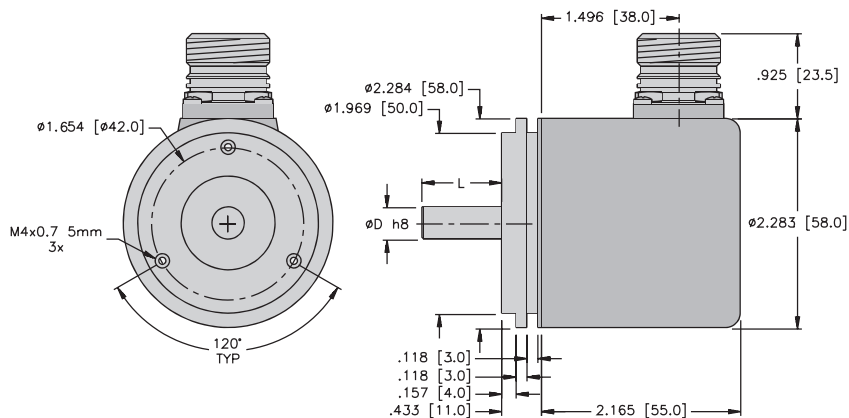

Mounting advice:

The flanges and shafts of the encoder and drive should not be rigidly coupled together at the same time. We recommend the use of suitable couplings (see page G1, Accessories).

Universal, type 580X (shaft) / 582X (hollow shaft)

Dimensions: 582X hollow shaft version

582X flange 1, 2 blind hollow shaft version (not available for 5826)
Connection C, 2(5826)

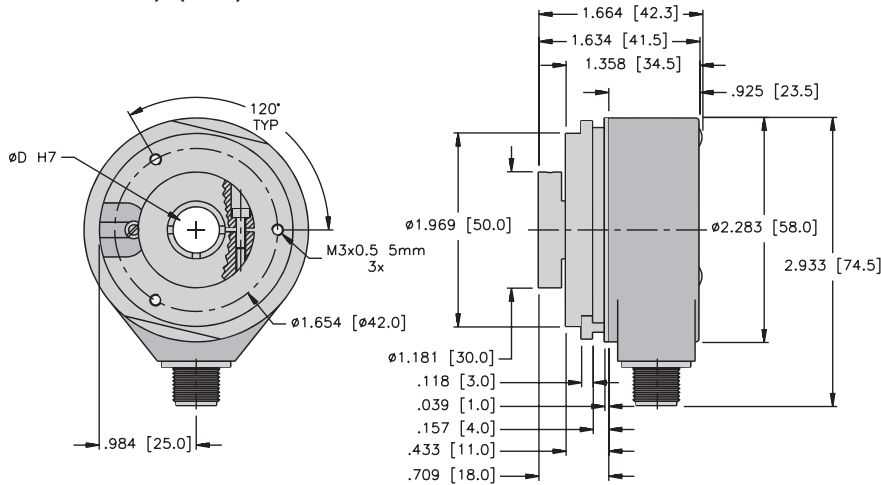

582X flange 3
Connection 1

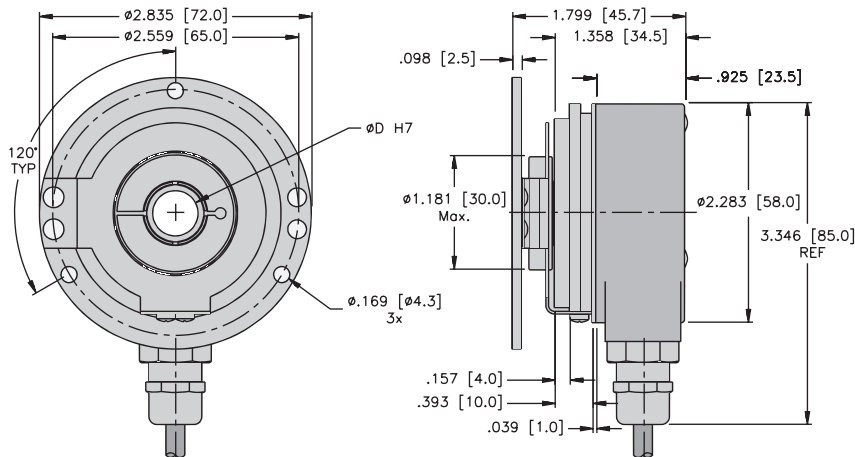

582X flange 4 blind hollow shaft option (not available for 5826)
Connection 2 (M23 connection not available for 5826)

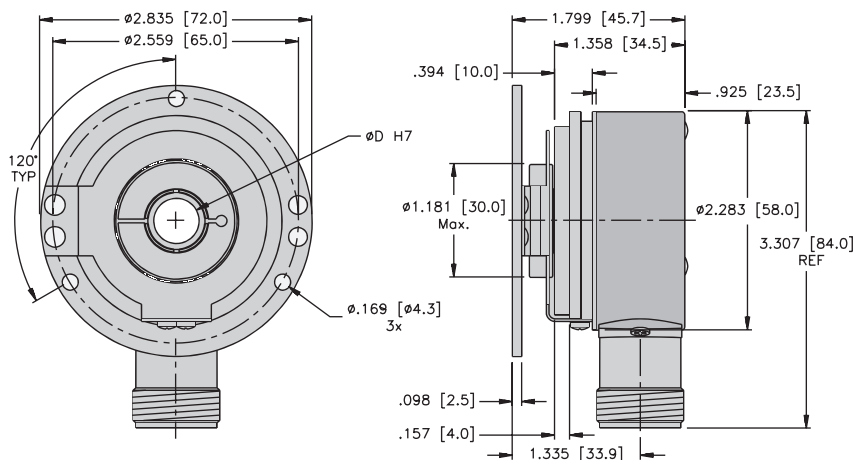

Mounting advice:

The flanges and shafts of the encoder and drive should not be rigidly coupled together at the same time.

When mounting a hollow shaft encoder, we recommend using a torque stop pin or a flex bracket (see page G1, Accessories).