

375 Finned Strip Heaters

Efficiently Conducts Heat From Nickel-Chrome Element Wire to the Sheath

The 375 finned strip heater from Watlow® is constructed of highly-compacted magnesium oxide (MgO) based insulation, which conducts heat efficiently from the nickel chromium element wire to the sheath. Two-inch wide (51 mm) nickel plated fins are attached to maximize surface contact allowing heat to transfer into the air faster. Lower sheath temperature and element life are maximized by this finned construction.

Performance Capabilities

- Aluminized steel sheath temperatures up to 1100°F (595°C)
- Watt densities up to 33 W/in² (5.1 W/cm²)
- UL® approved up to 240VAC (File No. E52951)
- CSA approved up to 600VAC (File No. LR7392)

Features and Benefits

Nickel-chromium element wire is centered in the heater

- Ensures uniform heat

Aluminized steel sheath

- Operates at higher temperatures and resists corrosion better than iron-sheathed heaters

Optional 430 stainless steel sheath

- Provides a durable solution for highly-corrosive environments

Welded post terminals

- Produces strong, trouble-free connections

Available lengths from 5½ to 48 in. (140 to 1220 mm)

- Fits a variety of application needs

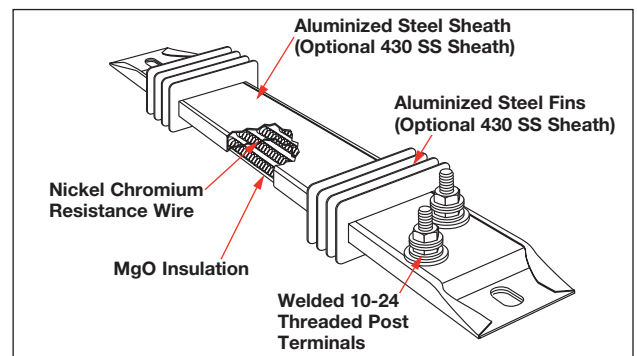

Typical Applications

- Enclosure heating
- Load bank resistors
- Shrink tunnels
- Duct heaters
- Space heaters
- Drying ovens
- Incubators
- Air heating
- Heat curing
- Ink drying
- Food warmers
- Moisture protection
- Dehumidifiers
- Stress relieving ovens

Technical Information

Calculating Watt Density

Use the graph and formulas to ensure the maximum allowable watt density for the heater is not exceeded in the application.

Open air watt density is calculated for the total heated surface area.

Formulas

$$\text{Watt Density} = \frac{\text{Wattage}}{\text{Heated Area}}$$

Heated Area

$$\begin{aligned} \text{(Offset Terminals)} &= [\text{Overall Length (A)} - 4 \text{ in.}] \\ &\quad \times 3.75 \text{ in.} \\ &= [\text{Overall Length (A)} - 102 \text{ mm}] \\ &\quad \times 95.3 \text{ mm} \end{aligned}$$

Heated Area

$$\begin{aligned} \text{(Parallel Terminals)} &= [\text{Overall Length (A)} - 3.12 \text{ in.}] \\ &\quad \times 3.75 \text{ in.} \\ &= [\text{Overall Length (A)} - 79.3 \text{ mm}] \\ &\quad \times 95.3 \text{ mm} \end{aligned}$$

Heated Area

$$\begin{aligned} \text{(One-on-One Terminals)} &= [\text{Overall Length (A)} - 4.25 \text{ in.}] \\ &\quad \times 3.75 \text{ in.} \\ &= [\text{Overall Length (A)} - 108 \text{ mm}] \\ &\quad \times 95.3 \text{ mm} \end{aligned}$$

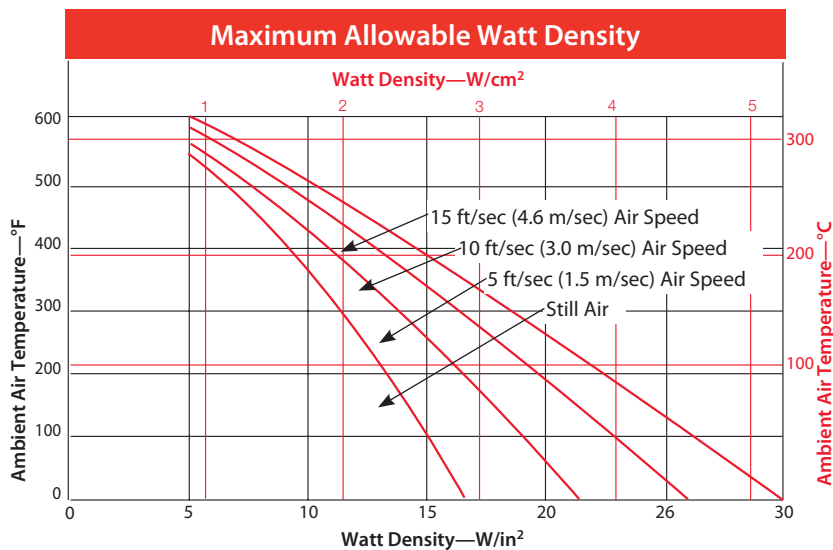

Termination Options

Offset Terminals

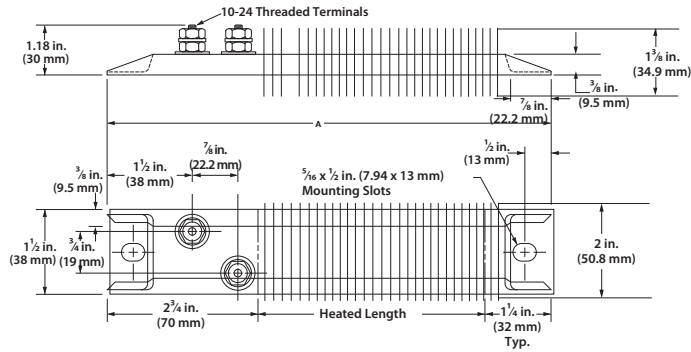

Two 10-24 threaded post terminals are offset from each other on the same end.

One-on-One Terminals

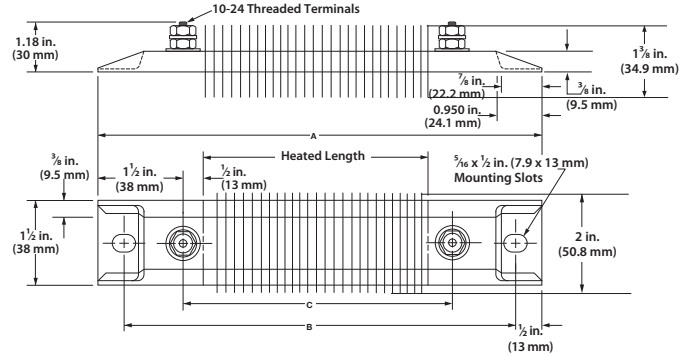

Two 10-24 threaded post terminals are placed one on each end.

Parallel Terminals

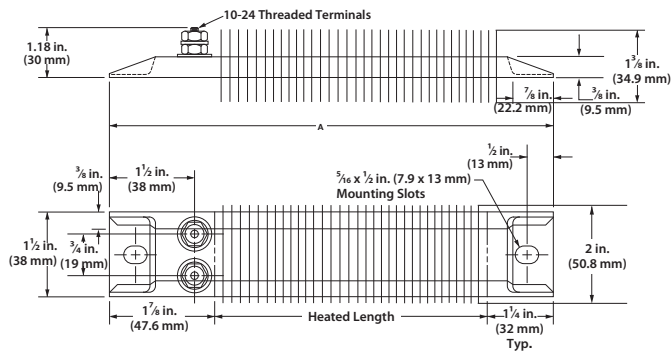

Two 10-24 threaded post terminals are used; both terminals on one end.

In-Line Terminals

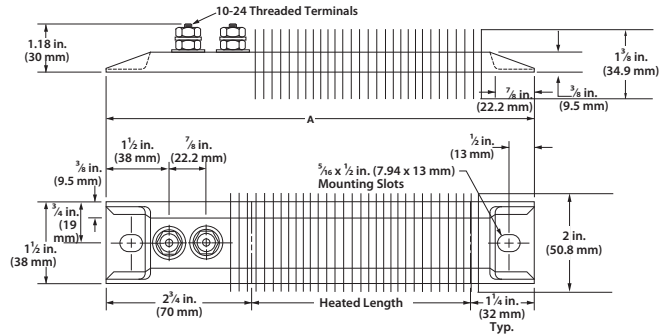

Two 10-24 threaded post terminals are in-line with each other on the same end.

Termination Options (Con't)

Metallic Terminal Boxes - Variations

Metallic terminal boxes are available from stock on offset terminals. Terminal boxes act as a safety feature by covering the terminals. A conduit may be attached to the box through $\frac{7}{8}$ in. (22.2 mm) diameter holes in the ends of the box. To order, specify **terminal box**.

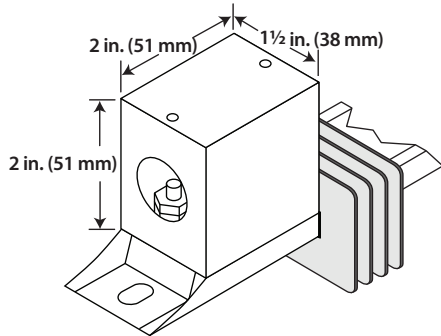

Available on in-line terminals only.

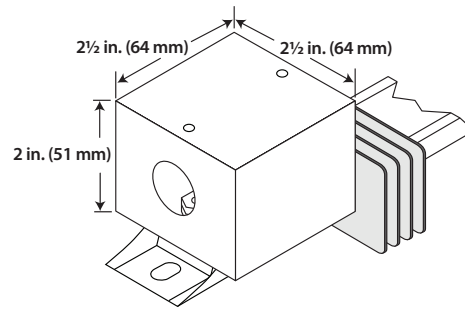

Available on offset terminals from stock and manufactured.

Accessories

Secondary Insulation Bushings

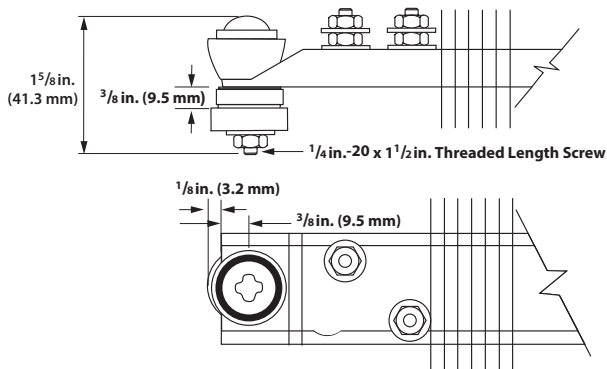

Insulators are suitable when air heating and/or voltage to ground is a concern. A secondary insulation bushing kit, part number **Z-5230**, contains one set of bushings for one heater. To accommodate bushings, $\frac{17}{32} \times \frac{11}{16}$ inch diameter mounting holes must be specified when ordering.

Note: Number of fins are dependent on length of heater.

Ceramic Terminal Covers

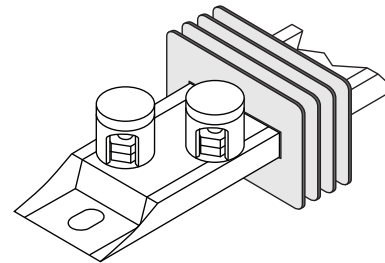

Ceramic terminal covers offer a convenient and economical method to insulate post terminals. A 10-24 screw thread is sized for standard length posts and is supplied as an accessory item and shipped separately. Specify **Z-4918** and quantity.

Watlow® is a registered trademarks of Watlow Electric Manufacturing Company.
UL® is a registered trademark of the Underwriter's Laboratories, Inc.

Powered by Possibility

To be automatically connected to the nearest
North American Technical Sales Office:
1-800-WATLOW2 • www.watlow.com
inquiry@watlow.com

International Technical Sales Offices:

Austria	+43 6244 20129 0	India	+91 40 6661 2700
China	+86 21 3532 8532	Italy	+39 02 458 8841
France	+33 1 41 32 79 70	Japan	+81 3 3518 6630
Germany	+49 7253 9400 0	Korea	+82 2 2169 2600

Mexico	+52 442 256 2200
Singapore	+65 6773 9488
Spain	+34 91 675 1292
Taiwan	+886 7 288 5168
UK	+44 115 964 0777